

Scope of application

Face Drill Rig WD 210D is built for 30m²- 120m² Drilling and anchor rod drilling operations for highway and railway tunnels, pumped storage power stations, hydro-power stations, irrigation tunnels in reservoirs, and underground caverns.

Main benefits

- › Fitted with electric proportional control system;
- › Equipped with computerized guidance system;
- › Self-adaptive pressure value when drilling, automatic anti-jamming reduces the consumption of drilling tools;
- › With water mist flushing system and blowing device to effectively remove stone slag in the hole.



Measurements

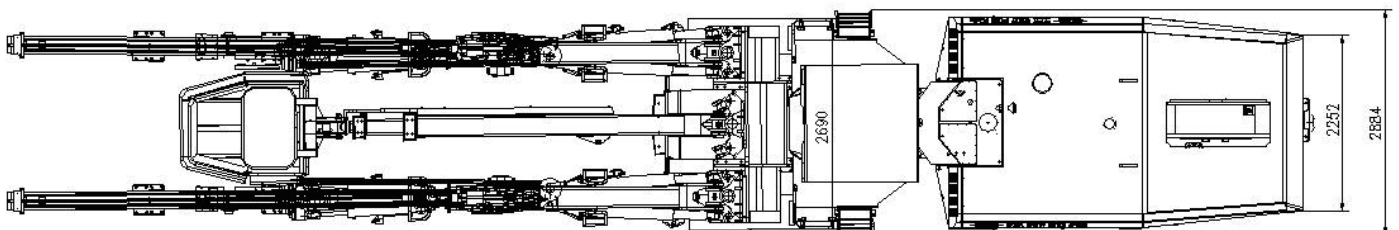
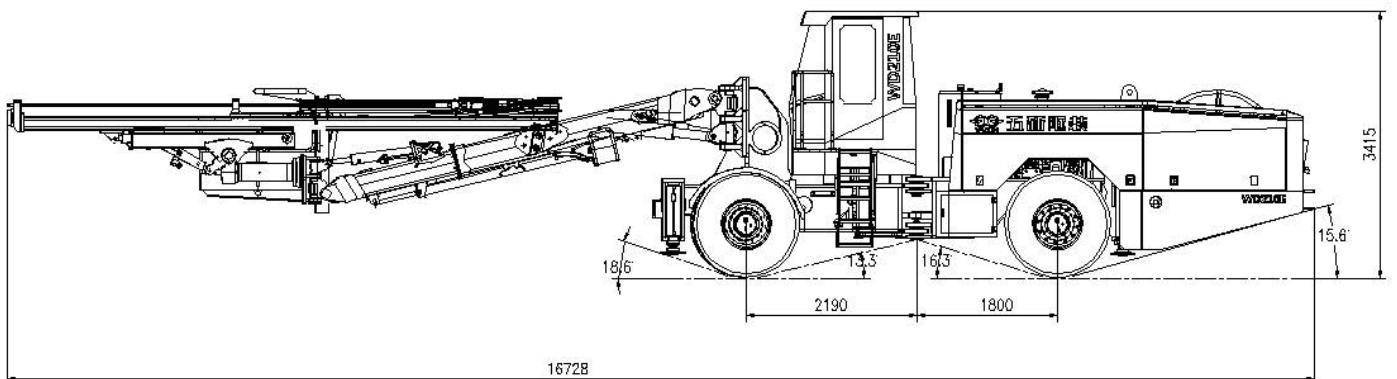

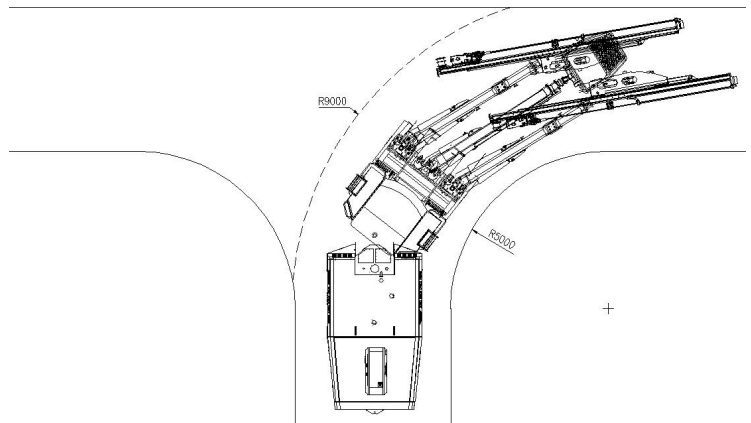
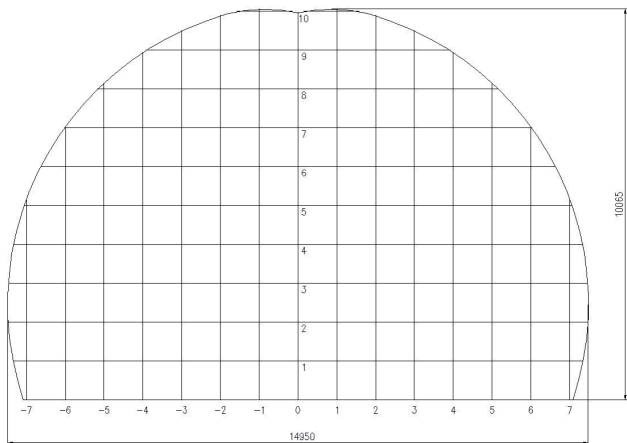

Technical specifications

Main parameters	
Total weight	37500kg
Length×Width×Height	16780×2880×3400mm
Scope of work (Width × Height)	14950×10000mm
Turning radius	External 7400 Interior 4700mm
Maximum coverage area	120m ²
Minimum height of tunnel	5m

Rock drill	
Model x Quantity	U1838ME
System pressure	210bar
Impact power	18kW
Impact pressure	230bar (Max)
Impact frequency	3600 (times/min)
Power per impact	300J
Rotating hydraulic oil pressure	210bar (Max)
Rotating torque	1000N·m (Max)
Rotation speed	210 (r/min)
Flushing water pressure	10 ~ 25bar
Quality	180kg

Drilling arm	
Quantity	2
Control mode	Computer control
Coverage area	120m ²
Telescopic stroke	2500mm
Swing and pitch angles	swing ±45° pitch -30° ~ +60°

Cable reel	
Main cable model	3×95 + 1×35
Cable length	100m

Feed	
Quantity	2
Type of feed	Cylinder-Wire Rope
Total length of feed	7180mm (Standard)
Advance Travel	1800mm
Maximum propulsive force	20kN
Length of drilling rod	5525mm (Standard)
Drilling diameter	41 ~ 89mm
One advance drilling depth	5200mm
Rotation angle	±180°
Pitch angle	±180°
Swinging angle	-15° ~ +70°

Operating platform	
Quantity	1
Scope of work (Height × Width)	12×16m
Lifting force	500kg
Telescopic stroke	5000mm

Drilling hydraulic system	
Hydraulic control mode	Electric proportional load sensitivity
Motor power x quantity	55kW×2
Rated pressure of main hydraulic oil pump	210 bar
Main hydraulic oil pump displacement	200L/min
Hydraulic oil tank capacity	350L
Pressure oil and return oil accuracy	10μm

Oil mist lubrication system	
Displacement / Pressure	1 (m ³ /min) / 8bar
Fuel consumption	4.8ml/min

Chassis	
Walking speed	15km/h
Climbing ability	25%
Ground clearance	300mm
Minimum inner radius of rotation	4700mm
Minimum outer radius of rotation	7400mm
Front and rear wheel wheelbase	4150mm
Front/rear wheelbase	2255/2255mm
Front/rear tire model x quantity	14.00R24×4
Transmission system	Four-wheel drive
Braking system	Hydraulic service brake + parking brake
Steering system	Articulated steering
Fuel tank volume	120L

Drilling rig control system	
Control type of drilling rig system	Computer control
Control panel type	Touch based
Electronic system power supply type	24V DC
Drill arm control type	Manual/semi-automatic

Water system	
Booster water pump model	KQDP
Booster water pump power	7.5kW
Rated displacement	160L/min
Rated pressure	10bar
Water pressure during drilling	10 ~ 15bar

Electrical system	
Total input power	130kW
Voltage/Frequency	380V/55Hz
Cable length and reel capacity	100m
Security protection system functions	Phase sequence and overload protection